

TANDBERG Connecting the Video Switch



The Video Switch set contains:

- 1 Video Switch Unit
- 4 Rubber Feet
- 1 HD Camera cable (1 m) for 6000MXP Codec
- 1 HD Camera cable (1 m) for 3000MXP Codec
- 1 Power supply kit incl. cables for Video Switch
- 1 Power supply kit incl. cables for existing camera
- 1 Rack ear set (left and right)
- 1 Control cable (6.5m) for Video Switch to Precision HD camera
- 1 HDMI cable (6.5m) for Video Switch to precision HD camera
- 1 TRC4 TANDBERG Remote Control

Please report any discrepancies immediately.

1 Unpack the unit.

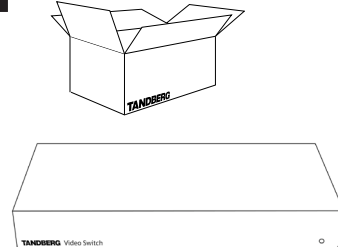

2 Mount the rack ears and/or rubber feet and mount it in the rack, if applicable.

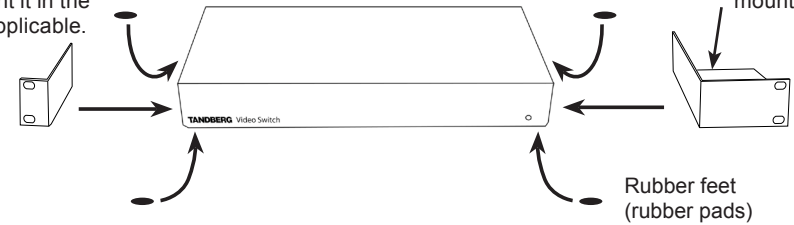

Put the Video Switch power supply here when rack mounting.

Rubber feet (rubber pads)

3 Connecting up to four TANDBERG Precision HD cameras:

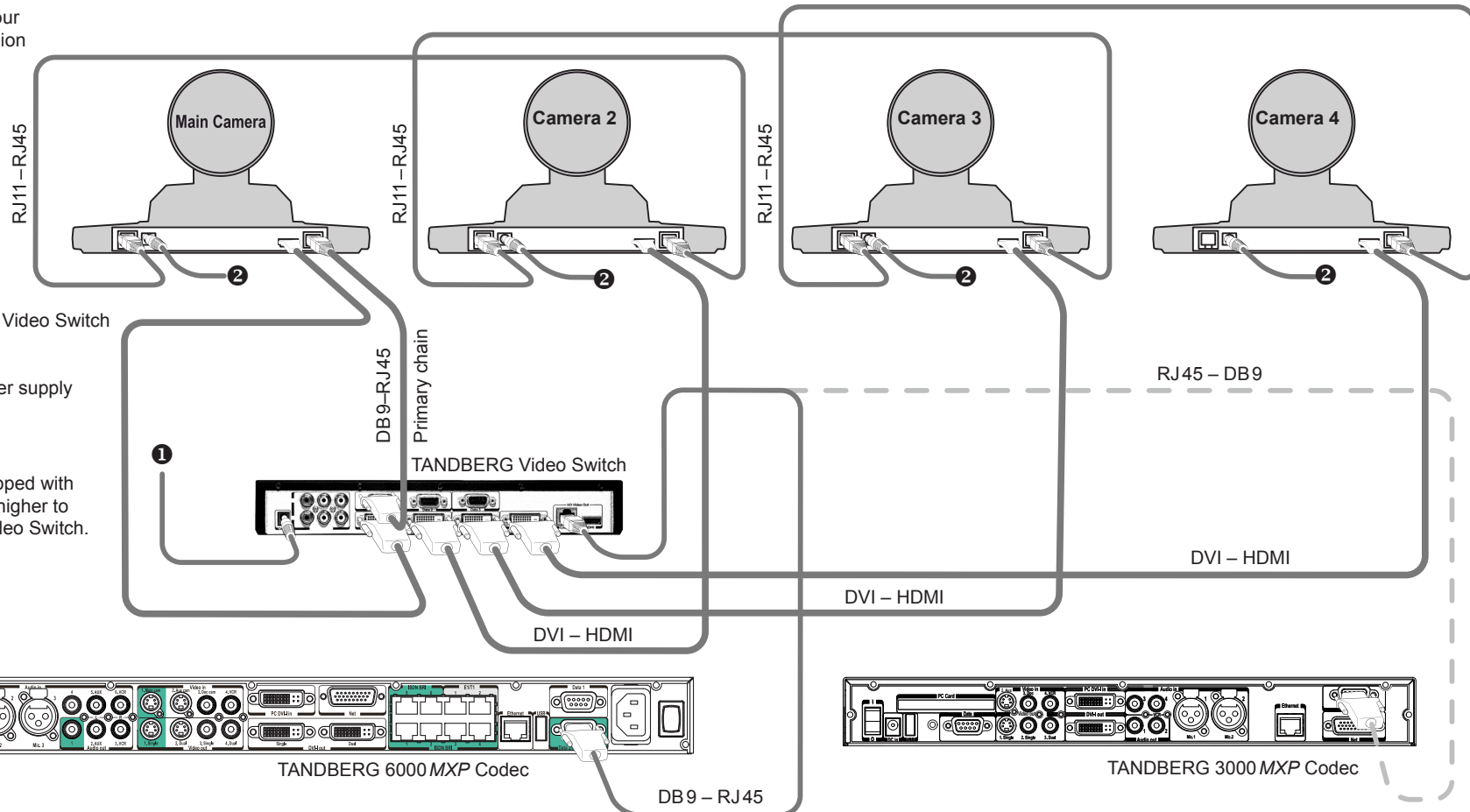

1 Connect TANDBERG Video Switch power supply here.

2 Connect camera power supply here.

The Codec must be equipped with software version F6.1 or higher to support the use of the Video Switch.

4 This diagram shows the additional connections needed to expand from using up to four TANDBERG Precision HD cameras (see overleaf) to also include up to three TANDBERG WAVE II cameras (i.e. up to seven cameras in total). Connect Video Switch power supply as shown overleaf.

Note! Start by connecting the Precision HD cameras as shown overleaf. The connection shown here comes in addition to the one overleaf!

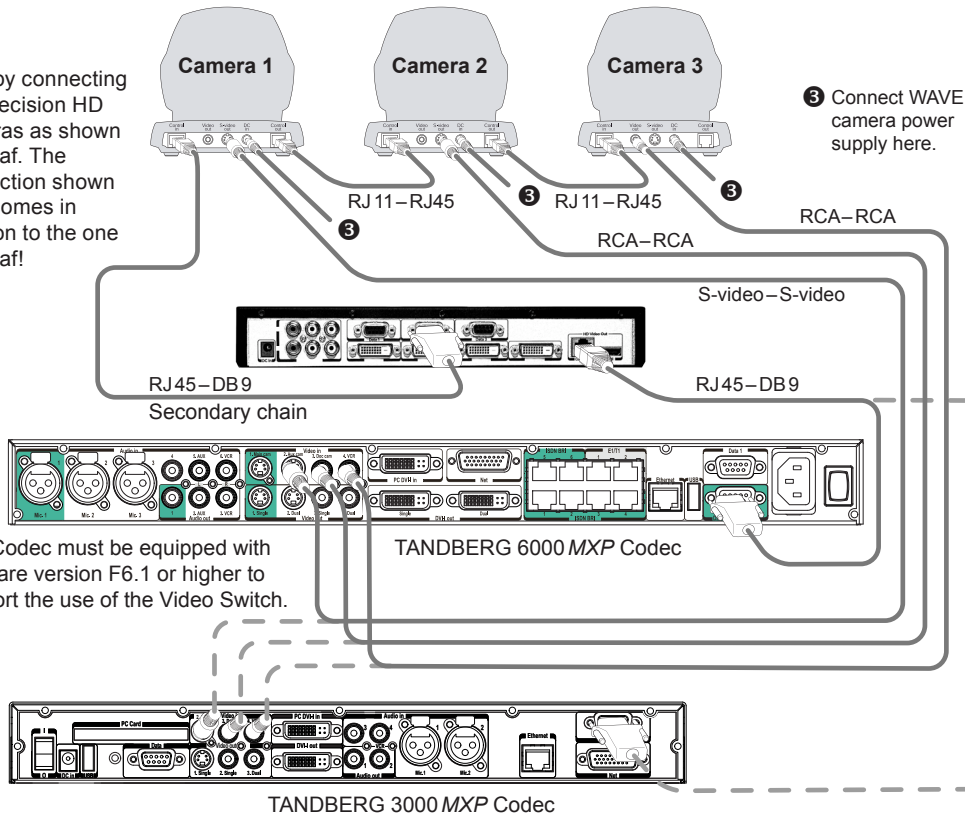

The Codec must be equipped with software version F6.1 or higher to support the use of the Video Switch.

5 This diagram shows the connections needed to use a maximum of two analog sources equipped with component video outputs. Connection diagram uses Sony EVI-HD1 cameras as example. System supports 1280X720p50, 1280X720p59.94, and 1280X720p60 only. For full VISCA control Sony EVI-HDI cameras or true compatibles must be used. Connect Video Switch power supply as shown overleaf.

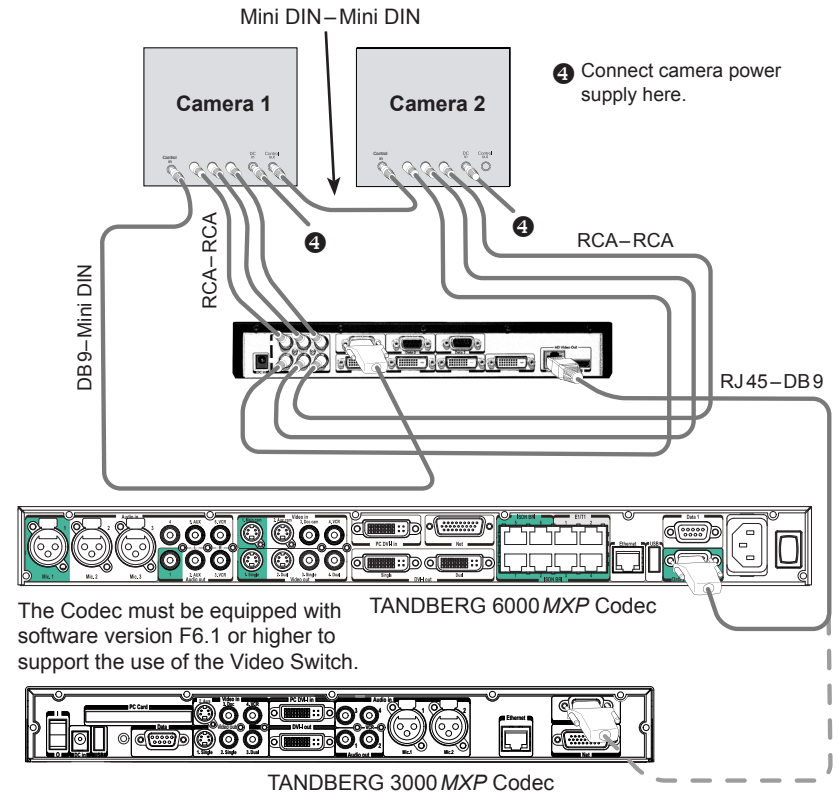

The Codec must be equipped with TANDBERG 6000 MXP Codec software version F6.1 or higher to support the use of the Video Switch.

To upgrade the software of the Precision HD camera, connect the camera directly to the main camera socket of the Codec (the socket that otherwise is used when connecting the Video Switch to the Codec).

Power the units and the upgrade will start automatically. The status will be shown on the video system's monitor.

RJ45-DB9 pinout is described in the TANDBERG MXP Reference User Guide for System Integrators, which came with your TANDBERG Codec.

TANDBERG RJ45-RJ11

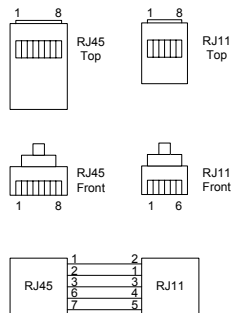

SONY Mini DIN Precision HD RJ11

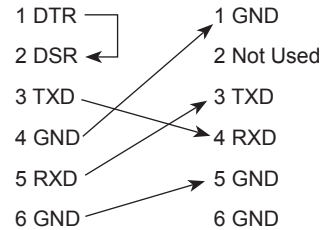

SONY Part Numbers:

DB9-Mini DIN cable

SONY part number RC893

Mini DIN-Mini DIN chain cable

SONY part number RC815

You may combine TANDBERG HD Precision cameras with analog sources equipped with component video outputs. Just add them to the chain of cameras in the diagram shown overleaf, but make sure the added sources appear after the TANDBERG HD Precision cameras in the chain (i.e. after camera 4 in the diagram overleaf).

Consequently, up to four TANDBERG HD Precision cameras may be combined with up to two analog component video sources and up to three TANDBERG WAVE II cameras, bringing the maximum number of video sources (which in many cases will be all cameras) up to nine!

Installation of the Video Switch

The Codec must be equipped with software version F6.1 or higher to support the use of the Video Switch.

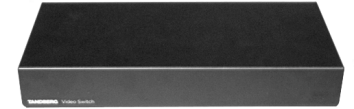

Basic Functionality

Physical inputs refer to explicit codec input and explicit switch input. These can only be controlled from the command interface. `xconfiguration MainVideoSource`, `vidin` and `xconfiguration Switch Source` always control the inputs directly.

Example: To select physical input 3 on the codec, use `xconfiguration MainVideoSource: 3`, as usual. To see inputs on the switch, select codec input 1 with `xconfiguration MainVideoSource: 1`, and select switch input with `xconfiguration Switch Source <1..6>`.

Logical inputs are used when accessing inputs from the menu, remote control and FECC. There are five input buttons on the top of the TRC4 remote control, and these can be remapped to any switch input you wish. The same five buttons are visible in the Presentation/Main Video menu, and these will be remapped in the same manner. If the switch is connected with no special configuration, selecting "main cam" in the menu will give the current input on the switch.

Example: There are two cameras connected to the switch, which we want to access from the menu and remote using the "main cam" and "aux" buttons:

`xconfiguration Switch LogicalInput 1 Mode: On`
`xconfiguration Switch LogicalInput 1 Map: 1`
`xconfiguration Switch LogicalInput 2 Mode: On`
`xconfiguration Switch LogicalInput 2 Map: 2`

You can rename the inputs using the standard `xconfiguration Video Inputs Source <1..6> Name` or `vidname`:

`xconfiguration Video Inputs Source 1 Name: "HD Camera 1"`
`xconfiguration Video Inputs Source 2 Name: "HD Camera 2"`

Note: If you select a switch input that has no mapping from the command interface, it will be called `Switch-<1..6>`. If you select a codec input that has been remapped to the switch from the command interface, it will be called `Codec-<1..5>`.

Command Interface – Configurations

Important: All camera configurations will get new ranges, 1..13 instead of 1..4. These will behave as follows if a switch is connected:

- 1 will be the switch.
- 2..7 will be cameras connected to secondary chain (chain originating from Data port 2 of the switch).
- 8..13 will be cameras connected to the primary chain (chain originating from Data port 1 of the switch).

Since the switch is the first entry in both chains, there is a max of 6 cameras per chain. This numbering scheme will be as compatible as possible with existing camera support. We open up for the possibility

to chain more cameras than 4 in the secondary chain. This will also be possible when the switch is not connected.

`xconfiguration MainVideoSource/DuoVideoSource <1..6>`

Will not be changed. 1 will mean current input on the switch.

`xconfiguration switch source: <1..6>`

Specify which input source to use on the switch. This will only cause a visible change if `MainVideoSource` is 1.

`xconfiguration switch config primary: <on/off>`

Default is on. If off, the codec will only do a basic setup of the primary chain and report what kind of cameras are connected. The codec will not set up brightness, whitebalance, gamma etc. for each camera. Turn it off if an external control system handles all the configuration.

`xconfiguration switch config secondary: <on/off>`

Default is on. If off, the codec will only do a basic setup of the secondary chain and report what kind of cameras are connected. The codec will not set up brightness, whitebalance, gamma etc. for each camera. Turn it off if an external control system handles all the configuration.

`xConfiguration Switch LogicalInput [1..5] Mode: <On/Off>`
`xConfiguration Switch LogicalInput [1..5] Map: <1..6>`

Default is `LogicalInput [1..5] Mode: Off`.

1. Main cam
2. Aux
3. Doc cam
4. VCR
5. PC

Remaps the source buttons on top of the extended remote control. Will also remap inputs selected from the menu, and change FECC accordingly. If mode for a key is on, the table entry will be used to specify which input on the switch to activate.

Command Interface – New Commands

Important: All camera commands will get new ranges, 1..13 instead of 1..4. This will work as specified in the section above.

The new commands below are also useful if there is no switch connected.

`xcommand CameraReconfigure`

Reconfigures all cameras connected to the switch or codec. This may be useful if you connect new cameras without turning the power off, since the switch does not autodetect such changes.

`xcommand CameraUpgrade <1..13> <filename>`

Upgrade camera or switch with new software. The software must be put on either `/tmp` or `/user`. Camera software files are named `s01692.pkg`. Switch software files are named `s51200.pkg`. Currently only upgrading of the first camera/switch is supported.

New Statuses

`xstatus switch`

Information about software version and ID will be given by `xstatus camera 1`. `xstatus switch` will give information about sync status for the active input, the format, and sync status for all DVI-D inputs.

`xstatus switch`

*s Switch (connected=True):

Input: 1
Format: 1280X720p60
Sync: True
Sync 1: True
Sync 2: True
Sync 3: False
Sync 4: False

Active input may differ from what is given in the `xconfiguration Switch Source` setting. This is because an external control system may also change the input.

Communicating with the Video Switch

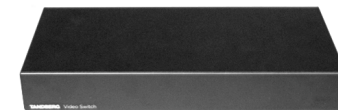

Communicating Using VISCA

Note! This section applies only to users wanting to control the switch directly from an external control system connected to Data port 3 on the switch.

The following describes how to communicate with the TANDBERG Video Switch using the VISCA protocol. For details about the protocol implementation, refer to the System Integrators Guide – Interfacing to the TANDBERG Wave 2 Camera.

VISCA Interface Basics

The TANDBERG Video Switch (TVS) uses a RS-232 control interface that resembles the Sony VISCA protocol.

TVS is configured in exactly the same way as a VISCA camera. TVS will always be located first in the camera chain(s).

The main jobs of the VISCA interface in the TVS are:

- Select which video source to use
- Route VISCA messages to the connected cameras
- Control picture resolutions sent to the codec

Cameras chained to the switch will start with id 2. The codec will automatically recognize this and map the cameras accordingly.

VISCA Serial Ports

The switch has a total of 4 serial ports that communicate using the VISCA protocol.

- Port 0, on the THSI interface, is always connected to the codec.
- Port 1 is the primary VISCA chain for cameras connected to the Switch.
- Port 2 is the secondary VISCA chain for the cameras that normally are connected to codec video inputs 2-5. See the section on Enhanced VISCA below.
- Port 3 is intended for external control systems, and works in the same way as port 0, but with some limitations on available commands. It is comparable to running the daisy port on a TANDBERG Precision HD Camera in dualvisca mode.

This article covers the use of port 3 as the control port for the switch. You *may* use port 0 if you do not intend to use the THSI interface, but only use HDMI out.

Enhanced VISCA

Since the switch has two possible camera chains, all normally formatted commands will be sent to the primary chain. To access the secondary chain, you must first turn Enhanced VISCA on with the **SW_eVisca** command.

Commands going to the secondary chain must be prefixed with **FE 01**. Replies from the secondary chain will also be prefixed with **FE 01**. You will only receive push messages from the secondary chain if Enhanced VISCA is turned on.

Important: Since the switch can receive VISCA from either the codec or an external control system, and since there are two possible camera chains, there are limitations on how commands are issued and answered:

- Only one command can be processed at a time
- Sending a new command when you receive an ACK from a Sony camera is not allowed. ACK messages will be thrown away by the switch
- Reply will always go to the source that issued the command.
- Sony push messages will be sent to both sources.

If this is not expected behaviour, an external control system may, of course, be setw to control all connected cameras directly via VISCA.

VISCA Messages

Commands that are prefixed with SW_ are new for the switch. The CAM_ prefix is used for commands that are copied from TANDBERG Precision HD Camera, or are standard VISCA messages.

VISCA Standard Commands

Command	Command Packet	Comments
CAM_IF_Clear	8x 01 00 01 ff	Clear command buffer. Stop any current operation in progress.
CAM_Address_Set	8x 30 0p ff	p = address for this device. If x=8 (broadcast), increase p with 1 before sending to chain.
CAM_Command_Cancel	8x 2p ff	p = Socket ID. Not supported in TVS
CAM_Power	8x 01 04 00 0p ff	p = 2: Power on. p = 3: Power off.

VISCA Standard Inquiries

Command	Command Packet	Comments
IF_DeviceType_Inq	8x 09 00 02 ff	y0 50 gg gg hh hh jj jj kk ff gggg = Vendor ID hhhh = Model ID jjjj = ROM Revision kk = Max sockets (No support for this in the TANDBERG Video Switch. Ignore it.)
CAM_Power_Inq	8x 09 04 00 ff	y0 50 0p ff p = 2: Power on. p = 3: Power off.

VISCA Standard Push Messages

Command	Command Packet	Comments
CAM_Network_Change	x0 38 ff	This indicates that cameras have been added to or removed from the camera chain. To avoid issues with (some) Sony cameras, the control system or codec should delay 9 seconds before reconfiguring the chain.

Configuration Commands

Messages starting with 8x-01-40-<00..1f> are configuration commands.

Command	Command Packet	Comments
SW_Port_0_Cfg	8x 01 40 00 ... ff	Currently not in use.
SW_Port_1_Cfg	8x 01 40 01 ... ff	Currently not in use.
SW_Port_2_Cfg	8x 01 40 02 0p ff	p=0: Disable this port p=1: Enable this port as a secondary VISCA chain port for cameras usually connected to codec input 2-5 (default). p=2: Use this port as a debug port.
SW_Port_3_Cfg	8x 01 40 03 0p ff	p=0: Disable this port p=1: Enable this port as a dual visca port (default). p=2: Use this port as a debug port.
SW_Port_x_Push_Cfg	8x 01 40 04 0p 0q 0r ff	Configure which push messages to send for given port. p=0/3: Configure port 0 or 3. qr bit 0: Enable/disable SW_Input_Push. qr bit 1: Enable/disable SW_Sync_Push. qr bit 2: Enable/disable Enhanced VISCA. qr = 00 is default for both ports.

Switch control commands

Messages starting with 8x-01-40-<20..3f> are switch control commands.

Command	Command Packet	Comments
SW_Input_Set	8x 01 40 20 0p ff	Sets which input to use. p=0..5 This will generate a SW_Input_Push on the THSI Visca port if issued from the dual visca port and vice versa.

Misc.

Command	Command Packet	Comments
CAM_Boot	8x 01 42 ff	Reboot the switch. This will also reset serial speed to 9600.

Inquiries

Messages starting with 8x-09...

Command set	Command Packet	Reply and comments
CAM_ID_Inq	8x 09 04 22 FF	Reply: 90 50 zz xx 00 yy FF zz xx = switch rev, zz=0x40 for TVS yy = firmware rev
CAM_SWID_Inq	8x 09 04 23 ff	Reply: x0 50 [1-125 bytes SWID] ff.
SW_Input_Inq	8x 09 40 20 ff	Reply 90 50 0p ff p=Active input, 0..5
SW_Sync_Inq	8x 09 40 e0 0p ff	Input: p=Input 0..5 Reply: 90 50 0p ff p=2: Input has sync p=3: No sync on input
SW_InputFormat_Inq	8x 09 40 e1 ff	Reply: 90 50 0p 0q ff pq = Format for active input. 0 = 720p60 1 = 720p59.94 2 = 720p50

Push Messages

Command set	Push Message	Comments
SW_Input_Push	x0 01 40 20 0p ff	The input has been changed. p = the new input source
SW_Sync_Push	x0 01 40 e0 0p 0q ff	Sync state has changed on an input. This one will also be sent if the format is changed, so if sync is on, send a SW_Format_Inq. p = source 0..5 q = state: 2 = sync, 3 = no sync

Disclaimer

The information in this document is furnished for informational purposes only, is subject to change without prior notice, and should not be construed as a commitment by TANDBERG. TANDBERG reserves the right to amend any of the information given in this document in order to take account of new developments.

Every effort has been made to supply complete and accurate information, however, TANDBERG assumes no responsibility or liability for any errors or inaccuracies that may appear in this document, nor for any infringements of patents or other rights of third parties resulting from its use. No license is granted under any patents or patent rights of TANDBERG.

For your protection please read these safety instructions completely before you connect the equipment to the power source. Carefully observe all warnings, precautions and instructions both on the apparatus and in these operating instructions.

Retain this manual for future reference.

A 级声明(A Class product declaration)

本产品为 A 级 ITE，在其使用说明、铭牌等显著位置中已包含如下内容的声明(We declare here that the subject product is A Class ITE product, and the following statement is clearly marked in the user manual and nameplate :

声明

此为 A 级产品，在生活环境中，该产品可能会造成无线电干扰。在这种情况下，可能需要用户对其干扰采取切实可行的措施。

WARNING:

This is a class A product. In a domestic environment this product may cause radio interference in which case the user may be required to take adequate measures.

声明所在位置 Position of the Declaration:

公司 Company Name:

TANDBERG Telecom AS

签字/盖章 Signature/ Stamp:



Water and Moisture

- Do not operate the apparatus under or near water – for example near a bathtub, kitchen sink, or laundry tub, in a wet basement, near a swimming pool or in other areas with high humidity.
- Do not touch the product with wet hands.

Cleaning

- Unplug the apparatus from communication lines, mains power-outlet or any power source before cleaning or polishing. Do not use liquid cleaners or aerosol cleaners. Use a lint-free cloth lightly moistened with water for cleaning the exterior of the apparatus.
- Unplug the apparatus from communication lines before cleaning or polishing. Do not use liquid cleaners or aerosol cleaners. Use a lint-free cloth lightly moistened with water for cleaning the exterior of the apparatus.

Ventilation

- Do not block any of the ventilation openings of the apparatus. Never cover the slots and openings with a cloth or other material. Never install the apparatus near heat sources such as radiators, heat registers, stoves, or other apparatus (including amplifiers) that produce heat.
- Do not place the product in direct sunlight or close to a surface directly heated by the sun.

Lightning

Never use this apparatus, or connect/disconnect communication cables or power cables during lightning storms.

Dust

Do not operate the apparatus in areas with high concentration of dust.

Vibration

Do not operate the apparatus in areas with vibration or place it on an unstable surface.

Power Connection and Hazardous Voltage

- The product may have hazardous voltage inside. Never attempt to open this product, or any peripherals connected to the product, where this action requires a tool.
- This product should always be powered from an earthed power outlet.
- Never connect attached power supply cord to other products.
- In case any parts of the product has visual damage never

attempt to connect mains power, or any other power source, before consulting service personnel.

- The plug connecting the power cord to the product power supply serves as the main disconnect device for this equipment. The power cord must always be easily accessible.
- Route the power cord so as to avoid it being walked on or pinched by items placed upon or against it. Pay particular attention to the plugs, receptacles and the point where the cord exits from the apparatus.
- Do not tug the power cord.
- If the provided plug does not fit into your outlet, consult an electrician.
- Never install cables, or any peripherals, without first unplugging the device from its power source.
- Always use the power supply (AC–DC adapter) provided with this product.
- Replace only with power supply (AC–DC adapter) specified by TANDBERG.
- Never connect the attached power supply (AC–DC adapter) to other products.

Servicing

- Do not attempt to service the apparatus yourself as opening or removing covers may expose you to dangerous voltages or other hazards, and will void the warranty. Refer all servicing to qualified service personnel.
- Unplug the apparatus from its power source and refer servicing to qualified personnel under the following conditions:
- If the power cord or plug is damaged or frayed.
- If liquid has been spilled into the apparatus.
- If objects have fallen into the apparatus.
- If the apparatus has been exposed to rain or moisture
- If the apparatus has been subjected to excessive shock by being dropped.
- If the cabinet has been damaged.
- If the apparatus seems to be overheated.
- If the apparatus emits smoke or abnormal odor.
- If the apparatus fails to operate in accordance with the operating instructions.

Accessories

Use only accessories specified by the manufacturer, or sold with the apparatus.

Communication Lines

Do not use communication equipment to report a gas leak in the vicinity of the leak.