

1. Streaming on/off
2. Still image capture
3. LED indicators
4. Microphone
5. Streaming indicator (red = streaming/recording on)
6. Light
7. Lens
8. SD memory card slot
9. External power connector
10. Antenna
11. Headset connector
12. Audio line in (plug in external audio source)
13. S-Video in (plug in external video source)
14. USB host interface
15. Ethernet port
16. Stylus
17. Viewfinder
18. Send button
19. End button
20. Zoom/Manual focus controls
21. Navigation pad
22. Speaker
23. Focus button
24. Display mode button
25. Recording On/Off
26. Power
27. Tripod mount
28. Battery door
29. Battery lock

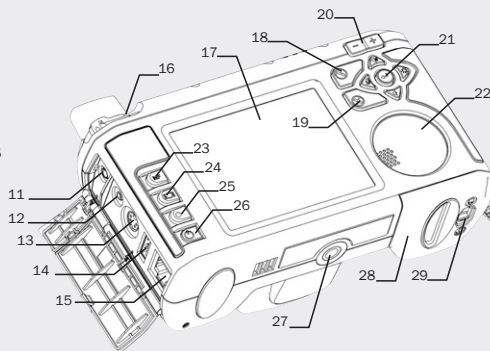
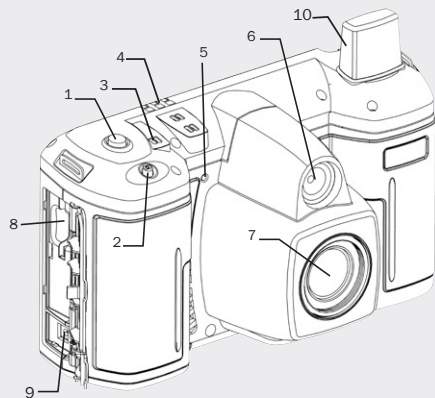

On unpacking the FieldView you should find:

- FieldView Device
- External Power Adapter
- Stylus
- Battery
- Wrist Strap
- Quick Start Guide (this document)
- CD of user guides, end-user license agreement and FieldView Application software
- Safety and regulatory information.

Before You Start. The FieldView Device is designed to communicate with a FieldView Application software client on a PC, using a network that has already been set up and configured.

- For more information on operating the FieldView Device, see the FieldView Device User Guide provided on the TANDBERG FieldView CD.
- For information on the FieldView Application software client, see the FieldView Application User Guide provided on the same CD.

Charging the Battery

Important: Before using this device for the first time you must install and charge the battery. The device will not operate on the external adapter alone. You must have a battery installed.

1

Slide the lock switch to the **Unlocked** position.

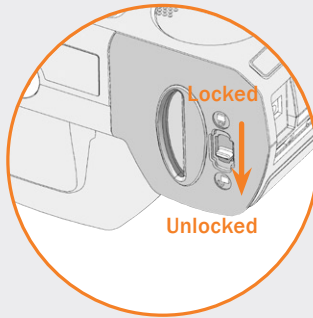

2

Open the battery compartment and insert the battery until it clicks into place and is flush. It fits one way only.

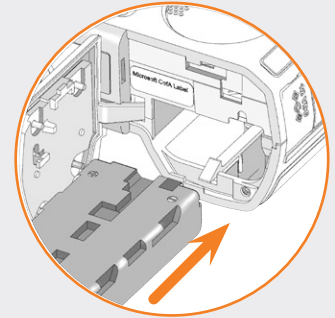

3

Close the battery door as follows:

- Ensure lock switch is in the **Unlocked** position.
- Orient the battery door so it is flat against the battery well, but with a 3 mm gap.
- Slide the door toward the centre of the FieldView Device until it is fully closed.

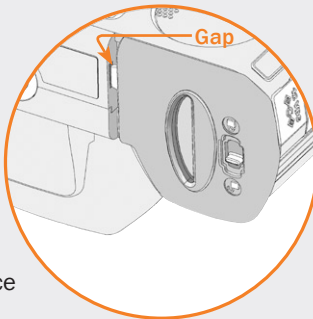





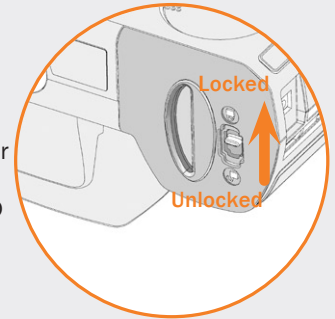

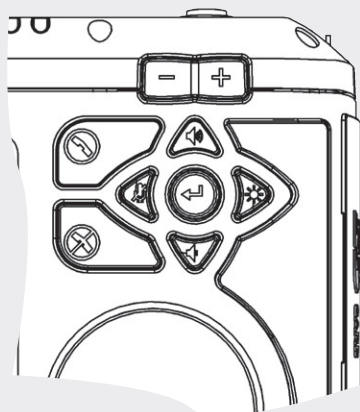

4

Slide the lock switch to the **Locked** position.
Connect the FieldView Device to the external power adapter and charge the battery until the orange LED turns off (up to 8 hours).





Navigation Pad



Button	Function
	Start or accept call (Send)
	End a call
	Volume up
	Mic mute
	Volume down
	Front illumination light on/off
	Enter

LED Indicators

	Power	Green = On or Standby
	Network	Green = Network available Off = Network unavailable
	Battery	Orange = Battery is charging Off = Battery is charged, or power is not connected.

Turning Power On

If the FieldView Device is **Off** or in **Standby** mode, press and release the **Power** button.

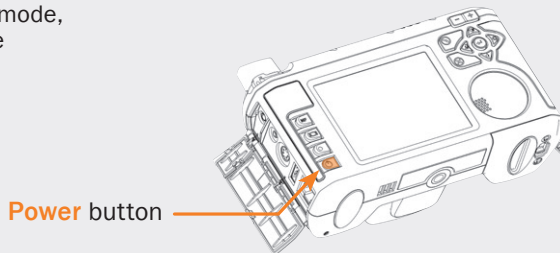

Going to Standby or Off

Going to Standby

Press and release the **Power** button to go to **Standby** mode. The **Viewfinder** turns off to use less power, but the **Power LED** remains illuminated.

Note: The unit will automatically enter **Standby** mode if it is **On**, but not used for a period (default 2 minutes).

Turning Power Off

If the unit is **On** or in **Standby** mode, press and hold the **Power** button for two seconds to turn it **Off**.

Logging in

If your installation requires a login, you will be prompted with a login screen on the Viewfinder, as shown below. To fill this in:

1. Tap the **Username** field with the stylus and select your user name from the list (your site administrator will provide this to you).
2. Tap the **Password** field with the stylus. An onscreen keyboard will appear.
3. Use the stylus to tap characters to enter them in the **Password** field.
4. Tap the **Login** button to finish logging in.

Important: When you are using the Viewfinder screen, always use the stylus provided with the FieldView Device. Do not use other objects, as this could damage the Viewfinder screen.



Logging in on the Viewfinder screen

Turning Streaming On or Off

When a call has been established (you can talk to the other user), press the **Streaming** button on top of the FieldView Device to start streaming media to the FieldView Application software client. Press it again to stop streaming.

Streaming button

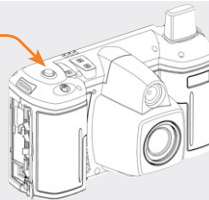

Displaying the Directory

Press the **Send** button to display the **Directory** window.

Starting a Call

Display the **Directory** and use the stylus or navigation pad to select a name from the **Local Contacts** list. Then press **Send** to start the call. You will hear outgoing rings or a busy signal.

Answering an Incoming Call

To answer a call, press **Send**.

Ending a Call

To end a call, press the **End** button.

TANDBERG
www.tandberg.com